

COPYRIGHT © Hangzhou EZVIZ Software Co., Ltd. ALL RIGHTS RESERVED.

Any and all information, including, among others, wordings, pictures, graphs are the properties of Hangzhou EZVIZ Software Co., Ltd. (hereinafter referred to as "EZVIZ"). This user manual (hereinafter referred to as "the Manual") cannot be reproduced, changed, translated, or distributed, partially or wholly, by any means, without the prior written permission of EZVIZ. Unless otherwise stipulated, EZVIZ does not make any warranties, guarantees or representations, express or implied, regarding to the Manual.

### **About this Manual**

The Manual includes instructions for using and managing the product. Pictures, charts, images and all other information hereinafter are for description and explanation only. The information contained in the Manual is subject to change, without notice, due to firmware updates or other reasons. Please find the latest version in the EZVIZ website (<http://www.ezviz.com>).

### **Revision Record**

New release – January, 2025

### **Trademarks Acknowledgement**

EZVIZ™,  and other EZVIZ's trademarks and logos are the properties of EZVIZ in various jurisdictions. Other trademarks and logos mentioned below are the properties of their respective owners.

### **Legal Disclaimer**

TO THE MAXIMUM EXTENT PERMITTED BY APPLICABLE LAW, THE PRODUCT DESCRIBED, WITH ITS HARDWARE, SOFTWARE AND FIRMWARE, IS PROVIDED "AS IS", WITH ALL FAULTS AND ERRORS, AND EZVIZ MAKES NO WARRANTIES, EXPRESS OR IMPLIED, INCLUDING WITHOUT LIMITATION, MERCHANTABILITY, SATISFACTORY QUALITY, FITNESS FOR A PARTICULAR PURPOSE, AND NON-INFRINGEMENT OF THIRD PARTY. IN NO EVENT WILL EZVIZ, ITS DIRECTORS, OFFICERS, EMPLOYEES, OR AGENTS BE LIABLE TO YOU FOR ANY SPECIAL, CONSEQUENTIAL, INCIDENTAL, OR INDIRECT DAMAGES, INCLUDING, AMONG OTHERS, DAMAGES FOR LOSS OF BUSINESS PROFITS, BUSINESS INTERRUPTION, OR LOSS OF DATA OR DOCUMENTATION, IN CONNECTION WITH THE USE OF THIS PRODUCT, EVEN IF EZVIZ HAS BEEN ADVISED OF THE POSSIBILITY OF SUCH DAMAGES.

TO THE MAXIMUM EXTENT PERMITTED BY APPLICABLE LAW, IN NO EVENT SHALL EZVIZ'S TOTAL LIABILITY FOR ALL DAMAGES EXCEED THE ORIGINAL PURCHASE PRICE OF THE PRODUCT.

EZVIZ DOES NOT UNDERTAKE ANY LIABILITY FOR PERSONAL INJURY OR PROPERTY DAMAGE AS THE RESULT OF PRODUCT INTERRUPTION OR SERVICE TERMINATION CAUSED BY: A) IMPROPER INSTALLATION OR USAGE OTHER THAN AS REQUESTED; B) THE PROTECTION OF NATIONAL OR PUBLIC INTERESTS; C) FORCE MAJEURE; D) YOURSELF OR THE THIRD PARTY, INCLUDING WITHOUT LIMITATION, USING ANY THIRD PARTY'S PRODUCTS, SOFTWARE, APPLICATIONS, AND AMONG OTHERS.

REGARDING TO THE PRODUCT WITH INTERNET ACCESS, THE USE OF PRODUCT SHALL BE WHOLLY AT YOUR OWN RISKS. EZVIZ SHALL NOT TAKE ANY RESPONSIBILITIES FOR ABNORMAL OPERATION, PRIVACY LEAKAGE OR OTHER DAMAGES RESULTING FROM CYBER ATTACK, HACKER ATTACK, VIRUS INSPECTION, OR OTHER INTERNET SECURITY RISKS; HOWEVER, EZVIZ WILL PROVIDE TIMELY TECHNICAL SUPPORT IF REQUIRED. SURVEILLANCE LAWS AND DATA PROTECTION LAWS VARY BY JURISDICTION. PLEASE CHECK ALL RELEVANT LAWS IN YOUR JURISDICTION BEFORE USING THIS PRODUCT IN ORDER TO ENSURE THAT YOUR USE CONFORMS TO THE APPLICABLE LAW. EZVIZ SHALL NOT BE LIABLE IN THE EVENT THAT THIS PRODUCT IS USED WITH ILLEGITIMATE PURPOSES.

IN THE EVENT OF ANY CONFLICTS BETWEEN THE ABOVE AND THE APPLICABLE LAW, THE LATTER PREVAILS.

# Table of Contents

|  |           |
|--|-----------|
| <b>Instruction</b>                                       | <b>1</b>  |
| <b>Packing List</b>                                      | <b>2</b>  |
| <b>Overview</b>  | <b>4</b>  |
| 1. Front Panel   | 4         |
| 2. Rear Panel  | 5         |
| <b>Installation</b>                                      | <b>6</b>  |
| 1. Installation Diagram                                  | 6         |
| 2. How to select the length of the Solenoids and Screws? | 7         |
| 3. View Installation Video                               | 7         |
| 4. Install Battery                                       | 8         |
| <b>Get the EZVIZ App</b>                                 | <b>8</b>  |
| <b>Lock Settings</b>                                     | <b>9</b>  |
| 1. Keypad  | 9         |
| 2. Enter Menu  | 10        |
| 3. Menu Index  | 11        |
| 4. Add Administrators/Users                              | 11        |
| 5. Add Fingerprint                                       | 12        |
| 6. Add Passcode  | 12        |
| 7. Add Proximity Card                                    | 13        |
| 8. Delete Administrators/Users                           | 13        |
| 9. Check the system information                          | 14        |
| 10. Delete Network Information                           | 14        |
| 11. Enter Matching Mode                                  | 15        |
| <b>Multiple Unlock Methods</b>                           | <b>15</b> |
| 1. Fingerprint Unlock                                    | 16        |
| 2. Passcode Unlock                                       | 16        |
| 3. Card Unlock   | 17        |
| 4. Mechanical Key Unlock                                 | 17        |
| 5. Synchronized Unlock                                   | 18        |
| 6. One-time Passcode                                     | 18        |
| 7. Child Safety Lock                                     | 18        |
| <b>Operation and Management</b>                          | <b>19</b> |
| 1. Emergency Unlock                                      | 19        |
| 2. Alarms  | 19        |

|                                      |    |
|--------------------------------------|----|
| 3. Restore to Factory Settings ..... | 19 |
| 4. Super Power-saving Mode.....      | 19 |
| 5. One-time Mute Function.....       | 19 |

## **Operations on the EZVIZ App ..... 20**

|                  |    |
|------------------|----|
| 1. Homepage..... | 20 |
| 2. Settings..... | 21 |

## **Maintenance..... 21**

|                           |    |
|---------------------------|----|
| 1. Daily Maintenance..... | 21 |
| 2. FAQ.....               | 22 |





## **Appendix ..... 23**



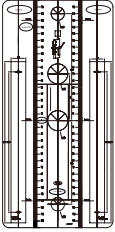
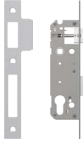
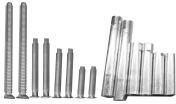

|   |    |
|---|----|
| 1. Rechargeable Lithium ion Battery .....   | 23 |
| 2. Information For Private Households ..... | 23 |

## Instruction

- The installation of EZVIZ Smart Lock (hereinafter referred as to "lock") impacts its normal operation and service life. It is recommended to let professionals install, and drill holes for the lock set according to the hole template in appendix.
- It is recommended to remove the lock if your house is under decoration, and reinstall it after decoration in case of lock damage and service life reduction.
- Please note that disinfectant may cause damage to the lock body.
- Once initialized completed, the lock will clear all user information. After lock installation and configuration, please add fingerprint, passcode or card as needed.
- When battery voltage is low after using for a while, low voltage alarm alerts. Charge battery timely.
- If you leave home or do not use lock for a long time, keep mechanical key with you, and do not leave it indoors. You should take battery out to ensure lock service life.
- Considering that the lock is put in an open environment, we suggest you pay attention to the safety in use, including keep properly small parts like the mechanical key or the proximity card. You should check the surrounding environment before unlocking and updating your passcode and proximity card settings on time as well in case of any danger of illegal stealing or copying of your unlock information.
- For users with flat or thin fingerprint, it is recommended to use thumb to register fingerprint for increasing success rate, and register more than one fingerprint each user. Each user supports a maximum of 5 fingerprints.
- The lock accommodates up to 50 fingerprints, 50 passcodes and 50 cards.
- The bio recognition technology in this product operates ENTIRELY LOCALLY on the product that you control and manage yourself, and only serves the sole purpose of supporting your decision of unlock. During the whole course, the saved data always only contains technical value, i.e. the biometric data obtained from the templates you proactively provided in advance (such as facial images, fingerprint template, palm vein template), which cannot be used to reconstruct the original data.

# Packing List

| NO. | Part Name          | Quantity | Image  |
|-----|--------------------|----------|--|
| 1   | Front Panel        | ×1       |     |
| 2   | Rear Panel         | ×1       |     |
| 3   | Hole Template      | ×1       |     |
| 4   | Lock Body          | ×1       |    |
| 5   | Standard Screw Bag | ×1       |  |
| 6   | Lithium battery    | ×1       |   |

| NO. | Part Name              | Quantity | Image  |
|-----|------------------------|----------|--|
| 7   | Mechanical key         | ×2       |   |
| 8   | Square Rod             | ×1       |  |
| 9   | Proximity Card         | ×2       |   |
| 10  | Regulatory Information | ×1       |   |
| 11  | Quick Start Guide      | ×1       |   |

 The appearance of the lock is subject to the actual one you have bought.

# Overview

## 1. Front Panel

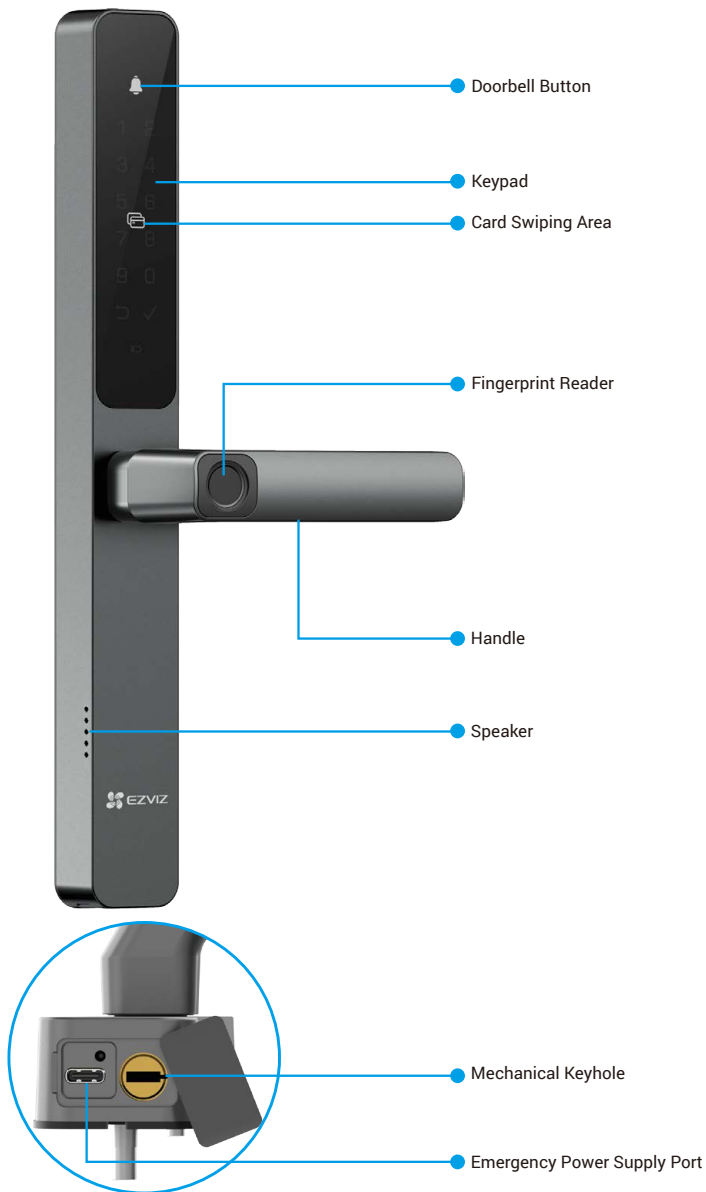

## 2. Rear Panel

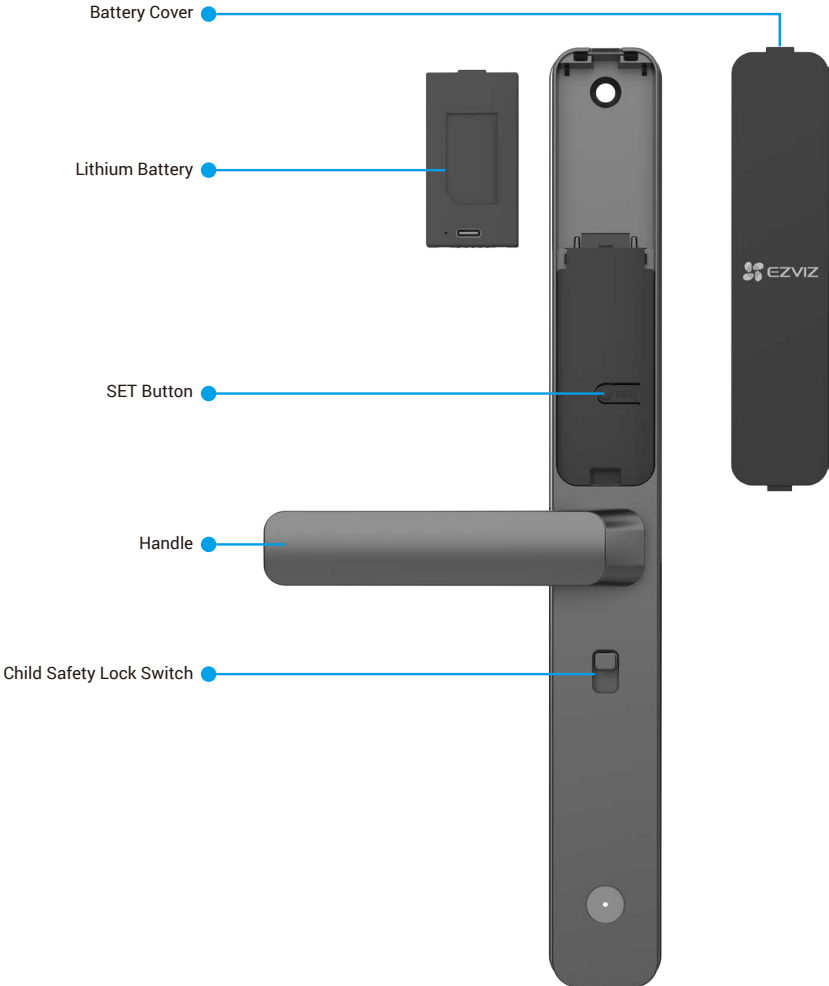

**i** The appearance of the lock is subject to the actual one you have bought.





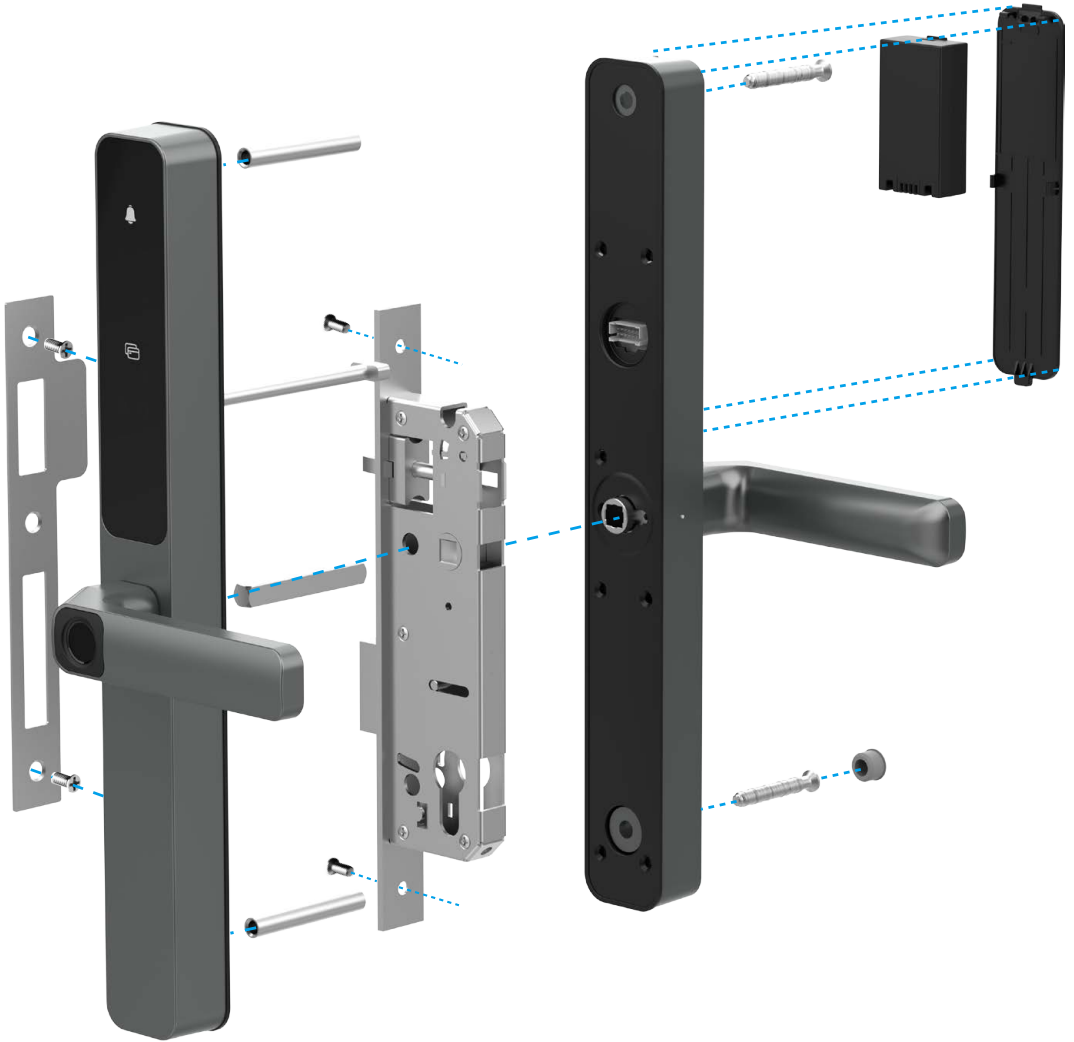





# Installation

## 1. Installation Diagram



## 2. How to select the length of the Solenoids and Screws?

Measure the door's thickness and select the appropriate solenoids and screws from the standard screw bag.

| The thickness of your door | The length of solenoids  | The length of screws   |
|----------------------------|--|--|
| 30 to 40mm                 | 25mm  | 20mm  |
| 40 to 55mm                 | 35mm  | 30mm  |
| 50 to 65mm                 | 35mm  | 40mm  |
| 60 to 85mm                 | 55mm  | 40mm  |
| 85 to 120mm                | 55mm  | 75mm  |

## 3. View Installation Video

Please tap  to watch the installation video.



## 4. Install Battery

1. After installation, remove the cover of battery slot from the rear panel.
2. Install the lithium battery into the battery slot.
3. Place back the battery cover.

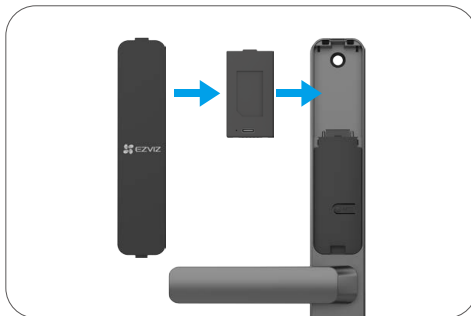

- For battery replacement, use the same model or equivalent specifications (refer to "[Rechargeable Lithium ion Battery](#)").
- To install a new battery, repeat the steps above.

## Get the EZVIZ App

1. Connect your mobile phone to 2.4GHz Wi-Fi (suggested).
2. Download and install the EZVIZ app by searching for "EZVIZ" in the App Store or Google Play™.
3. Launch the app and register an EZVIZ user account.

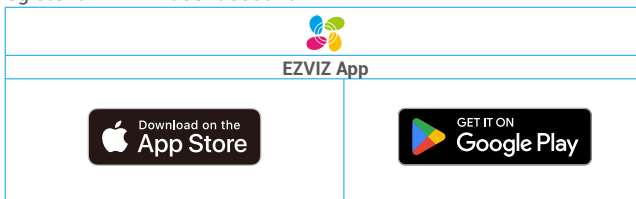

- If you have already used the app, please make sure that it is the latest version. To find out if an update is available, go to the app store and search for "EZVIZ".

## Add the Lock to EZVIZ

- The app interface may be different due to version update, and the interface of the app you installed on your phone shall prevail.

Please add the lock to EZVIZ app by following steps:

1. Log in to your EZVIZ app account.
2. On the Home screen, tap "+" on the upper-right corner to go to the Scan QR Code interface.
3. Press and hold the SET button on the rear panel until the lock sends a voice prompt and the keypad number 0 flashes to enter matching mode.

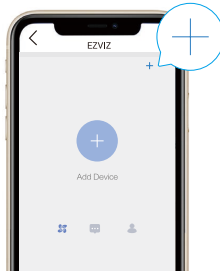

4. Scan the QR code on the back of the battery cover.

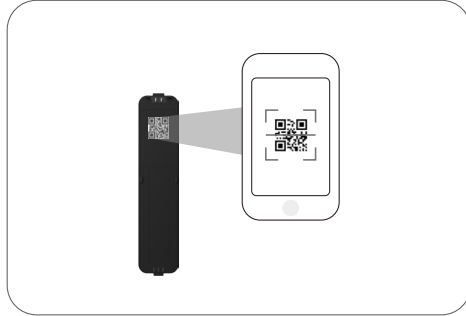

5. Follow the EZVIZ app wizard to add the lock to EZVIZ app account.

## Lock Settings

Then you can set the lock as needed.

**i** Please remove protective film from lock before the first use.

### 1. Keypad



| Icon | Description            |
|------|------------------------|
|      | number key             |
|      | cancel, return or exit |
|      | confirm                |
|      | card swiping area      |
|      | doorbell               |
|      | low-battery indicator  |

## 2. Enter Menu

 Please follow these steps for settings.

### • In initial state, follow these steps for settings.

1. Touch the keypad area of the front panel to activate the lock.
2. "⏏" "✓" on keypad light up, press "✓" add an administrator.
3. "1" "2" "3" "⏏" on keypad light up.
  - Press "1" to add a fingerprint.
  - Press "2" to add a passcode.
  - Press "3" to add a card.

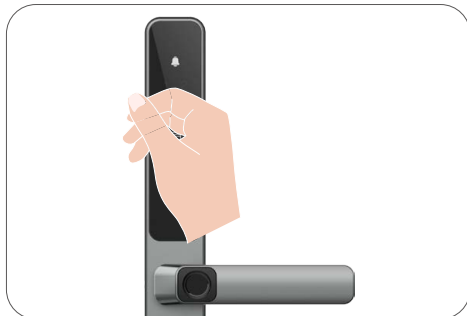

### • In non-initial state, follow these steps for settings.

1. Remove the battery cover from the rear panel.
2. Press the SET button once.
3. When the keypad is light up, verify with administrator's pre-set fingerprint, passcode, or card.
4. "1" "2" "3" "4" "5" "⏏" on keypad will light up.

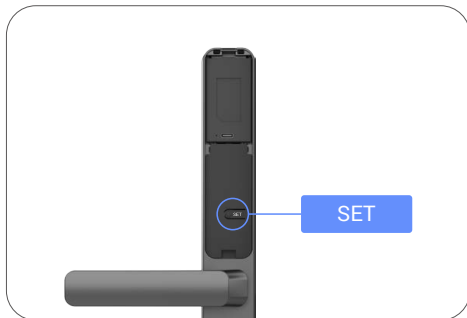

### 3. Menu Index

**i** The menu here is for reference only.

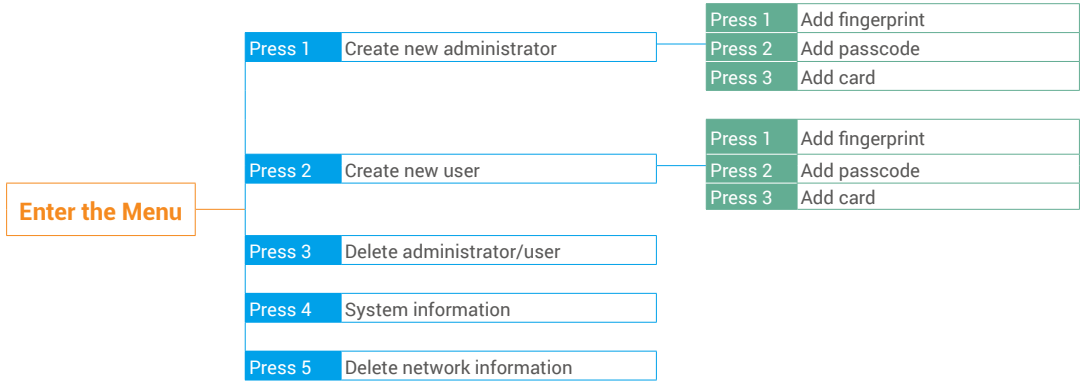

### 4. Add Administrators/Users

1. Press the SET button once on the rear panel.
2. When the keypad of the front panel is light up, verify with administrator's authentication key.
3. Press "1" to add an administrator, or press "2" to add a user.

| Role          | Unlock the door | Enter the Menu, and set the lock |
|---------------|-----------------|----------------------------------|
| Administrator | ✓               | ✓                                |
| User          | ✓               | X                                |

Ordinary users can only unlock the door after entering the opening method; the administrator can not only unlock the door, but also log in to the menu to add and delete users and operate other settings.

**i** When you add an administrator or a user, the user number digits will light up from 001 by default ( for example, to user number 001, the three numbers 001 will slow-flash once in sequence).

## 5. Add Fingerprint

- Add up to 5 fingerprints per user.
- Place your finger to fully cover the fingerprint reader, avoiding excessive pressure or tilted angles.

1. Press the SET button once on the rear panel.
2. When the keypad of the front panel is light up, verify with administrator's authentication key.
3. Press "1" to add an administrator, or press "2" to add a user.
4. Press "1" to add a fingerprint.

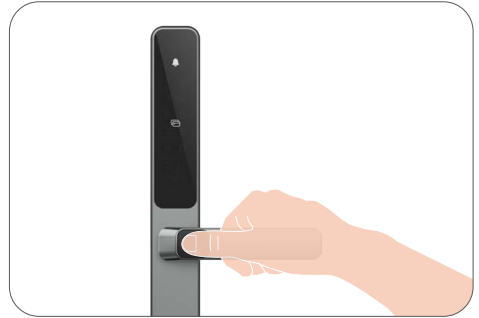
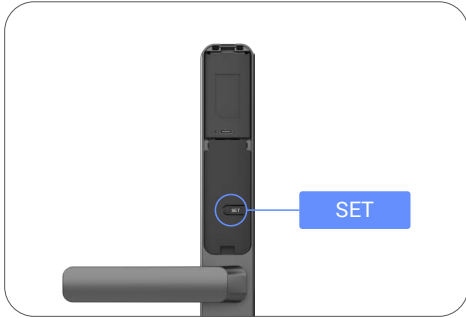

## 6. Add Passcode

- Add up to 1 passcode per user.

1. Press the SET button once on the rear panel.
2. When the keypad of the front panel is light up, verify with administrator's authentication key.
3. Press "1" to add an administrator, or press "2" to add a user.
4. Press "2" to add a passcode.
5. Enter a passcode with 6-10 digits. When the passcode length  $\geq 6$  digits, "✓" lights up at this time, press "✓" to confirm.
6. Repeat the passcode once again, press "✓" to confirm, accompanied by a success beep, the passcode is successfully added.

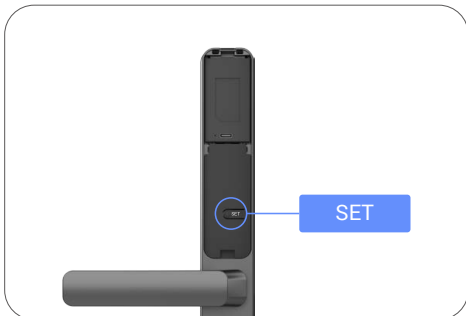

- 6-10 consecutive or repeated numbers are not allowed.
  - 6-10 consecutive digits, such as 123456/654321.
  - 6-10 repeated digits, such as 111111.

## 7. Add Proximity Card

**i** Add up to 1 proximity card per user.

1. Press the SET button once on the rear panel.
2. When the keypad of the front panel is light up, verify with administrator's authentication key.
3. Press "1" to add an administrator, or press "2" to add a user.
4. Press "3" to add a card.
5. Place the unrecorded proximity card on the card swiping area.
6. Press "√" to confirm.

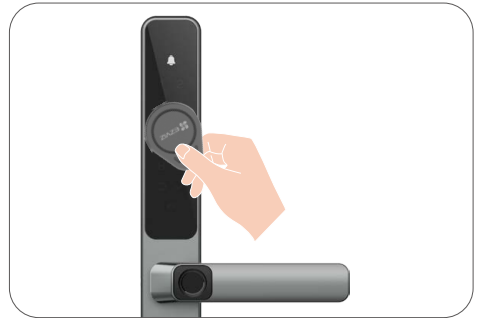
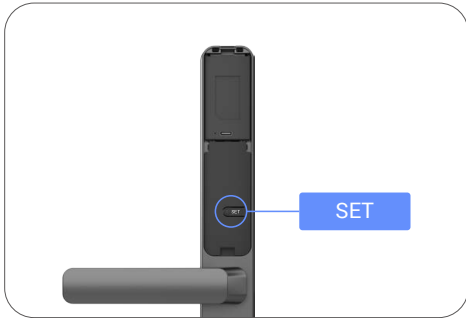

## 8. Delete Administrators/Users

1. Press the SET button once on the rear panel.
2. When the keypad of the front panel is light up, verify with administrator's authentication key.
3. Press "3" to delete an administrator/a user.
4. Enter the user number and press √.

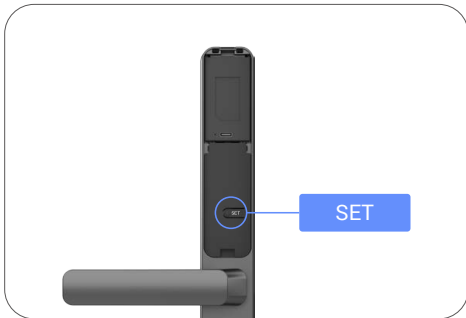

- i**
- If you pressed a wrong user number, you will see the user number light up one by one, accompanied by a failure beep. Press "↶" to return to last step, or enter the right user numbers to delete again.
  - When there is only one user left, and you operate to delete it, you will see the user number light up one by one, accompanied by a failure beep.
  - The last administrator can not be deleted.

## 9. Check the system information

1. Press the SET button once on the rear panel.
2. When the keypad of the front panel is light up, verify with administrator's authentication key.
3. Press "4" to check the system information of the lock.
4. The lock will broadcast the system information.

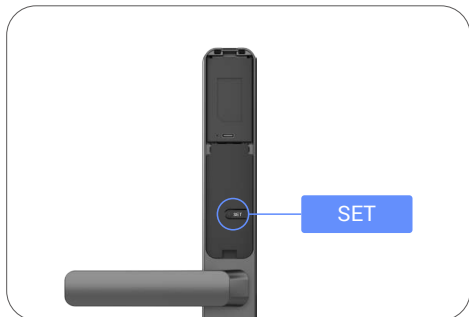

- i** The lock will broadcast the lock serial number, the current device version and verification code in English in turn, press  $\triangleright$  to return to the previous level. Or the system will return to the previous level automatically after the successful broadcast.

## 10. Delete Network Information

1. Press the SET button once on the rear panel.
2. When the keypad of the front panel is light up, verify with administrator's authentication key.
3. Press "5" to delete network information.
4. Press "√" to confirm.



- i** If you want to change your lock's Bluetooth, follow the steps above. For example: If you have already disconnected the Bluetooth matching from user A, and connect to another one.

## 11. Enter Matching Mode



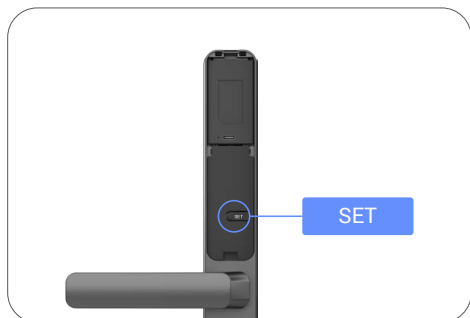



1. Press and hold the SET button on the rear panel until the lock sends a voice prompt and the keypad number 0 flashes to enter matching mode.



2. Please follow the system guide to finish the matching in 3 minutes.

 The system will exit the matching mode automatically after 3 minutes.

### Multiple Unlock Methods

| Icon  | Description           |
|---|-----------------------|
|    | Fingerprint unlock    |
|    | Passcode unlock       |
|   | Card swiping unlock   |
|  | Mechanical key unlock |
|  | Bluetooth key unlock  |
|  | Remote unlock         |

-  • To open the door with a mechanical key, rotate the key and press the handle downwards.  
• Please touch the keypad area to activate the lock before opening the door with the passcode.  
• For your privacy, it is recommended that you change the passcode regularly and clean the keypad area in case of remaining marks.



- Please note that this product has security protection function, if the fingerprint/passcode/card recognition error number reaches 5 times continuously in 5minutes, the system will be locked forcibly for 3 minutes.
- The system automatically unlocks after 3 minutes.
- This function can be disabled via the EZVIZ app.

## 1. Fingerprint Unlock

1. Put your finger on the fingerprint reader.
2. When you hear the voice prompt, put down the handle to open the door.

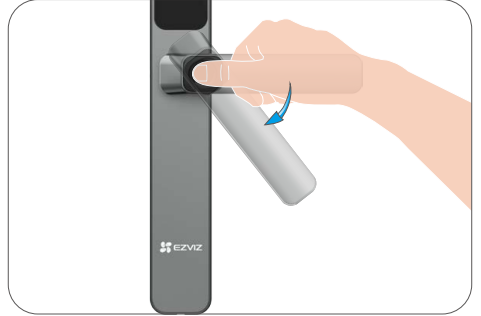
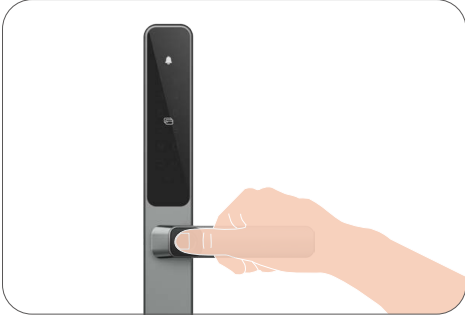

## 2. Passcode Unlock

1. The product is protected with Anti-Peeping passcodes. If someone is watching you enter a passcode, you can add extra long digits before or after your original code to make it more complex, while still being able to unlock it.

1. Touch to wake up the keypad.
2. Enter the passcode and press ✓.
3. When you hear the voice prompt, put down the handle to open the door.

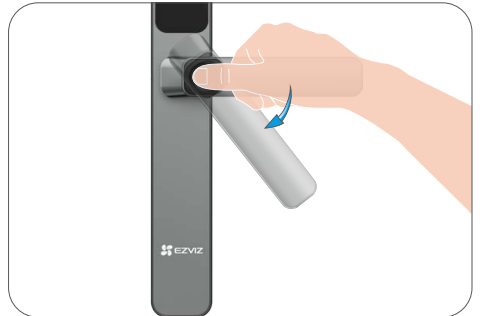
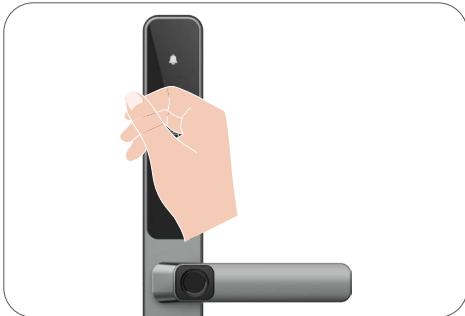

### 3. Card Unlock

1. Touch to wake up the keypad.
2. Place the recorded proximity card on the card swiping area.
3. When you hear the voice prompt, press down the handle to open the door.

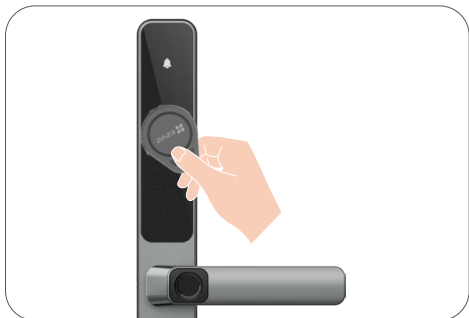
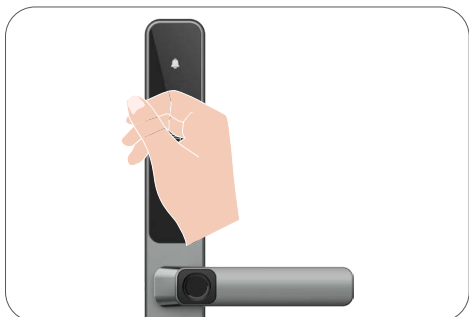

**i** When the 'Door Lock Actively Detects Proximity Card' function is enabled, the door lock automatically detects nearby proximity cards without touching the keypad.

**Operation:**

1. Log in to your EZVIZ app account.
2. Go to 'Settings' -> 'Unlock Settings' and tap to enable the 'Door lock actively detects proximity card'.

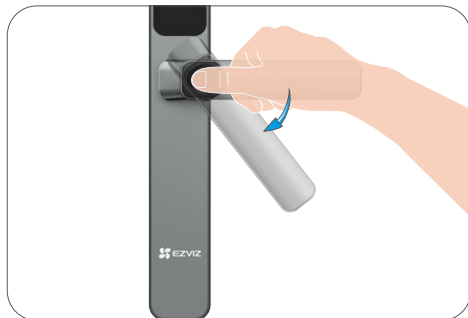

### 4. Mechanical Key Unlock

**i** Please keep the mechanical key properly for further use.

1. Open the cover of the mechanical keyhole.
2. Insert the key and rotate it, then put down the handle to open the door.

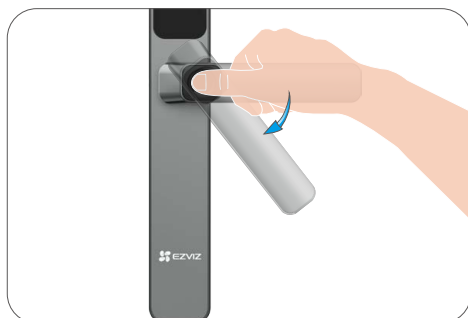
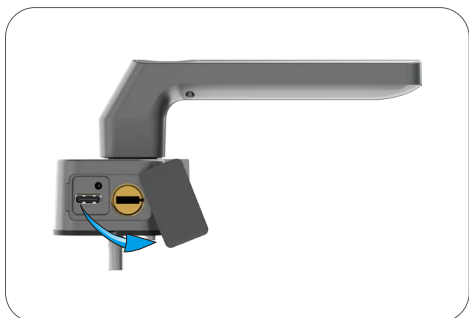

## 5. Synchronized Unlock

- i** You are enabling the feature of “Synchronized Unlock” (“The Function”). Please note that:
1. Considering the automatic unlock feature of The Function, we suggest that you:
    - a. only enable The Function when necessary and safe;
    - b. inform the shared users of your device(if any) to ensure they know what will happen.
  2. The function should be managed by the administrator user, and it may be subject to other settings of the device(eg. the Bluetooth function). Please refer to the page instructions for details.
  3. The Function is provided “AS IS”. EZVIZ hereby explicitly excludes any promises or guarantees regarding the stability, accuracy, and timeliness of The Function. And, EZVIZ may change, suspend, or terminate The Function and/or this page from time to time by notifying you in advance.

### Enable the Synchronized Unlock:

1. Log in to your EZVIZ app account.
2. Go to “Settings” -> “Unlock Settings” -> “Synchronized Unlock” and tap to enable the “Synchronized Unlock”.
3. Tap “Confirm to use” -> “Link Now”-> “Link Now”.
4. Tap to choose a lock you want to link, and tap “Link”.
5. Before the countdown ends, unlock the linked door with the administrator’s secret key to complete the lock linking operation.
6. Linked successfully.

- i**
- When the Function is enabled, unlocking the door from outside will simultaneously unlock the linked lock.
  - Remember to press down the handle of the linked lock within 10 seconds (default unlock duration), otherwise it will re-lock automatically.
  - The synchronization duration can be adjusted via the EZVIZ App.

## 6. One-time Passcode

When visitors arrive, you can create a one-time door passcode for them.

- i**
- The one-time passcode takes effect immediately after generation.
  - Once enabled, one-time passcodes can be generated even when the lock is offline.

## 7. Child Safety Lock

- i** It is advisable to enable the child safety lock mode when children are left alone at home.

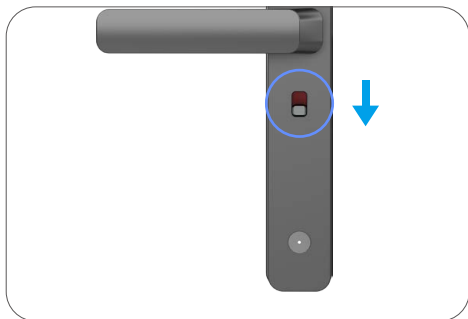

Child safety lock mode is enabled

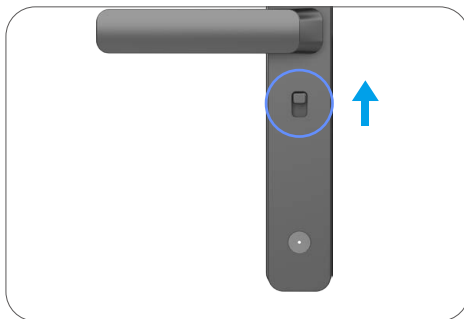

Child safety lock mode is disabled

- i** When the child safety lock mode is enabled, the door can't be unlocked by pressing the handle indoor. The door can only be unlocked through verifications by the added fingerprint, passcode or card outdoor.

# Operation and Management

## 1. Emergency Unlock

When battery is out of power, connect the emergency power supply interface of the front panel with power bank to charge the lock through Type-C power cable and then unlock the door.

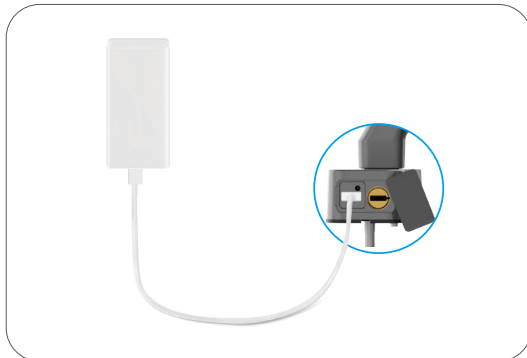

## 2. Alarms

### 1. Anti-tamper Alarm

Once being dismantled by force, the lock will send out alarm lasting about one minute.

### 2. System Locked Alarm

Verify with wrong fingerprint, passcode or card 5 times in a row, the system will be locked for 3 minutes. You can unlock it in the EZVIZ app.

### 3. Low Battery Warning

Once battery voltage is low, the voice prompt will remind you to charge battery.

## 3. Restore to Factory Settings

1. Remove the battery cover of rear panel and take out the battery.
2. Press the SET button for 5s, meanwhile put back battery in the battery slot.
3. Release the SET button and press ✓ to confirm after voice prompts.

## 4. Super Power-saving Mode

Add the Super Power saving mode, which improves battery performance and lasts longer.  
Opening method: Enter the battery management option from the Settings page.

## 5. One-time Mute Function

1. Touch the keypad area to wake up the keypad.
2. Press and hold "0" until the keypad flashes twice to indicate the function is on.

- When the one-time mute function is enabled, the lock enters silent mode.
- The lock will automatically exit this mode when it has been unlocked by verification with the added fingerprint, passcode or card from the outside.

# Operations on the EZVIZ App

**i** The app interface may be different due to version update, and the interface of the app you installed on your phone shall prevail.

## 1. Homepage

When you launch the EZVIZ app and tap your lock, you can view and manage the lock as needed on the homepage.

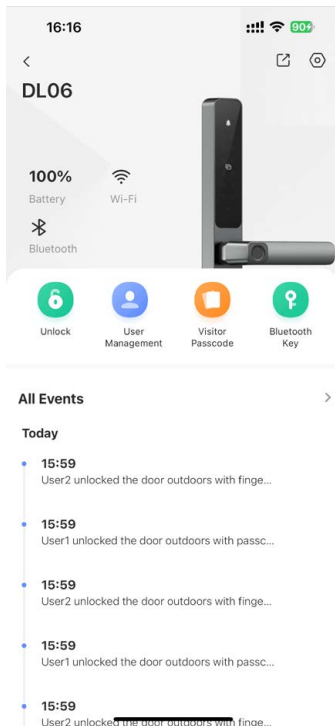

| Parameter        | Description  |
|------------------|--|
| Battery          | You can see the battery remaining capacity here.   |
| Wi-Fi            | You can see the Wi-Fi signal strength of the lock here.  |
| Bluetooth        | You can see the Bluetooth connection status here.  |
| Unlock           | Tap to unlock the lock.  |
| User management  | You can tap to manage the users here.<br><b>i</b> After adding a user, you can also add unlock methods for that user, such as fingerprint, digital passcode, proximity card, and duress passcode. Please note that the unlock method needs to operate on the lock. |
| Visitor passcode | Tap to generate a temporary access code for visitors to open the door.   |
| Bluetooth key    | Tap to share Bluetooth key to you family members or guests.  |
| All Events       | Check all events happened to the lock.   |

## 2. Settings

| Parameter            | Description   |
|----------------------|---|
| Name                 | View or tap to customize the name of your device here.  |
| Unlock Settings      | You can configure the unlocking settings for the lock here.   |
| Battery              | Check the battery capacity of the lock and tap to enable the Super Power-saving mode here.  |
| Message Notification | You can manage the device message and EZVIZ app notification.   |
| Audio Settings       | You can set relevant audio parameters for your device.  |
| Accessory Management | <ul style="list-style-type: none"><li>• Bluetooth Door Sensor: Once linked, you can view the door status detected by the door sensor on the lock's homepage page.</li><li>• Bluetooth Remote Control: Once linked, you can unlock the door with the remote control.</li></ul>   |
| Door Opening Log     | You can see the door-openings logs here.  |
| Privacy Settings     | <ul style="list-style-type: none"><li>• Privacy mode: When you enable the privacy mode, the door can only be unlocked with the fingerprint, passcode and proximity card of the administrator, or with the mechanical key. And the lock will mute at the same time.</li><li>• Trial and error lock: when enabled, the system will be locked for 3 minutes and you cannot use the electronic key to unlock when unlock errors reached 5 times in 5 minutes.</li></ul> |
| Network Settings     | <p>You can see the Wi-Fi connection status and set to enable/ disable the Wi-Fi connection.</p> <p> In the case of unstable network, it is recommended to disable this function to extend battery life.</p>  |
| Device Information   | You can see the device information here.  |
| Share Device         | You can share the device to <u>you</u> family members or <u>guests</u> .  |
| Delete device        | Tap to delete the lock from your EZVIZ account.   |

## Maintenance

### 1. Daily Maintenance

- Do not put corrosive materials near the lock to avoid lock damage and impacting its gloss.
- If door deforms, it increases friction that combined latch bolt entering the box strike plate and bolt cannot extend fully. At this time, adjusting strike plate position is needed.
- Charge the battery immediately once battery voltage is low to ensure the normal use of the lock.
- Keep the mechanical key properly.
- Ask professionals to check the lock if it is not flexible.
- Keep lubricant in the rotating part of the lock to keep it rotate smoothly and prolong its service life.
- It is recommended to check the lock once every six months or one year, and check whether fixed screws are loose.
- Apply a small amount of graphite powder or pencil powder into lock cylinder slot to ensure the key is inserted and removed smoothly on regular basis (one year or six months). However, do not apply any grease to lubricate in case of grease sticking to the pin tumbler spring.
- Please note that disinfectant may cause damage to the lock body.

## 2. FAQ

| Problem  | Cause   | Solution  |
|--|---|---|
| Door cannot be opened normally through verifications by fingerprint, passcode or card. | Lock installation issue   | Please have professionals recheck the installation.   |
|  | User authority is not within the validity period                                    | Please use fingerprints, passcodes or cards of other users, or update the user validity period through EZVIZ app.   |
| Door cannot be opened with mechanical key  | Incorrect mechanical key  | Use the correct mechanical key  |
|  | Lock cylinder is damaged  | After opening the door, please have professionals check and replace damaged components.   |
|  | The mechanical key cannot be fully inserted   |   |
| No response from fingerprint reader  | Fingerprint reader is damaged.  | Please have professionals recheck the installation.   |
|  | The fingerprint reader's firmware is running abnormally.                            | <ol style="list-style-type: none"> <li>1. Touch to wake up the keypad.</li> <li>2. Press and hold the "↵" for 3 seconds to restore the fingerprint reader.</li> </ol>   |
| The lock is always open.   | Installation error  | Please have professionals recheck the replacement.  |
|  | Clutch is damaged.  | Please have professionals recheck the installation.   |
| Unable to connect your mobile phone Bluetooth.   | Mobile phone Bluetooth is disabled  | Please enable your mobile phone Bluetooth and try to connect again.   |
|  | The distance between the lock and your mobile phone is out of Bluetooth range (50m) | Please get closer to the door lock for retry.   |
|  | Incorrect Pairing code  | <p>Please enter the correct pairing code.</p> <ol style="list-style-type: none"> <li>a. By default, the pairing code is 0 plus the last 5 digits of the serial number.</li> <li>b. Otherwise the pairing code is customized.</li> </ol> <p>If the pairing code is forgotten, clear the pairing information (refer to "<a href="#">Delete Network Information</a>"). The pairing code will then be restored to the default value and can be used for connection.</p> |
|  | Other reasons   | <ol style="list-style-type: none"> <li>a. Try again after restarting the Mobile phone Bluetooth.</li> <li>b. Try again after exiting and re-entering the EZVIZ app.</li> <li>c. Clear the pairing information (refer to "<a href="#">Delete Network Information</a>"), and then try again after operate to forget the pairing information between your phone and the lock</li> </ol>  |
| Users and fingerprints, passcodes, cards cannot be added on the EZVIZ app.             | Your mobile phone is not connected to the lock Bluetooth                            | Please connect the lock Bluetooth first, then add them in the user management on the EZVIZ app  |
| The device is often offline.   | Network environment is unstable   | Please change to a stable network signal  |

| Problem                         | Cause                           | Solution                                      |
|---------------------------------|---------------------------------|---|
| Fast battery power consumption. | Network environment is unstable | Please turn off the Wi-Fi switch on EZVIZ app |
|                                 |                                 | Please change to a stable network signal      |

 For additional information about the device, please refer to [www.ezviz.com/eu](http://www.ezviz.com/eu).

## Appendix

### 1. Rechargeable Lithium ion Battery

The battery type of the device: Portable battery.

Battery model: 692850HV-2S1P

Rated voltage: 7.7 V DC

Rated capacity: 1450mAh

Battery manufacturer: JUHEYUAN SCIENCE & TECHNOLOGY CO., LTD.

| Chemical Name                       | CAS No.    | Concentration or concentration ranges (%) | Chemical Formula   |
|-------------------------------------|------------|---|--------------------|
| Lithium Cobalt Oxide                | 12190-79-3 | 15-40                                     | LiCoO <sub>2</sub> |
| Graphite                            | 7782-42-5  | 10-30                                     | C                  |
| Phosphate(1-), hexafluoro-, lithium | 21324-40-3 | 10-30                                     | LiPF <sub>6</sub>  |
| Copper                              | 7440-50-8  | 7-13                                      | Cu                 |
| Aluminum foil                       | 7429-90-5  | 5-10                                      | Al                 |
| Nickel                              | 7440-02-0  | 1-5                                       | Ni                 |

### 2. Information For Private Households

1. Separate collection of waste equipment: Electrical and electronic equipment that has become waste is referred to as waste equipment. Owners of waste equipment must dispose of it separately from unsorted municipal waste. In particular, waste equipment does not belong in household waste, but in special collection and return systems.
2. Batteries and rechargeable batteries as well as lamps: Owners of waste equipment shall, as a rule, separate waste batteries and rechargeable batteries that are not enclosed in the waste equipment, which can be removed from the waste equipment without being destroyed, from the waste equipment before handing them in at a collection point. This does not apply if waste equipment is prepared for reuse with the participation of a public waste management authority.
3. Options for returning waste equipment: Owners of waste equipment from private households can return it free of charge to the collection points of the public waste management authorities or to the take-back points set up by manufacturers or distributors within the meaning of the Electrical and Electronics Equipment Law. Stores with a sales area of at least 400 m<sup>2</sup> for electrical and electronic equipment and those grocery stores with a total sales area of at least 800 m<sup>2</sup> that offer electrical and electronic equipment several times a year or on a permanent basis and make it available in the market are required to take it back. This also applies in the case of distribution using means of distance communication, if the storage and shipping areas for electrical and electronic equipment are at least 400 m<sup>2</sup> or the total storage and shipping areas are at least 800 m<sup>2</sup>. Distributors shall, in principle, ensure take-back by providing suitable return facilities at a reasonable distance from the respective end user. The possibility of returning waste equipment free of charge exists for distributors who are obliged to take it back, among other things, if a new similar device that essentially fulfills the same functions is delivered to an end user.
4. Privacy Notice: Waste equipment often contains sensitive personal data. This applies in particular to devices of information and telecommunications technology such as computers and smartphones. In your own interest, please note that each end user is responsible for deleting the data on the waste equipment to be disposed of.
5. Meaning of the symbol "crossed-out wheelee bin": The symbol of a crossed-out wheelee bin regularly depicted on electrical and electronic equipment indicates that the respective device is to be collected separately from unsorted municipal waste at the end of its service life.